

**E-ONE**  
 Ocala, FL  
 SO.000000  
 VT04 TRADITION PUMPER  
 FREIGHTLINER M2 2DR

1250 GPM HALE QFLO PUMP 1000 GALLON WATER TANK					HOSELOAD: NFPA COMPLIANT	
COMPT.	OPENING		INTERIOR DIMENSION			
L1	34W	68H	34W	14H	12D	UPPER LOWER
R1	34W	28H	34W	28H	24D	
L2	56W	36H	56W	40H	12D	
R2	54W	28H	54W	28H	24D	
L3	54W	68H	54W	40H	12D	UPPER LOWER
B1	36W	51H	38W	19H	17D	UPPER LOWER

THIS DRAWING IS FOR REFERENCE PURPOSES. ALL DIMENSIONS ARE SUBJECT TO MINOR VARIATIONS DUE TO MANUFACTURING PROCESSES.

This print is the property of Emergency One, Inc. and is loaned to you subject to return on demand, unless otherwise agreed to in writing by Emergency One, Inc. Its contents are confidential and must not be copied or submitted to third parties for use or examination.

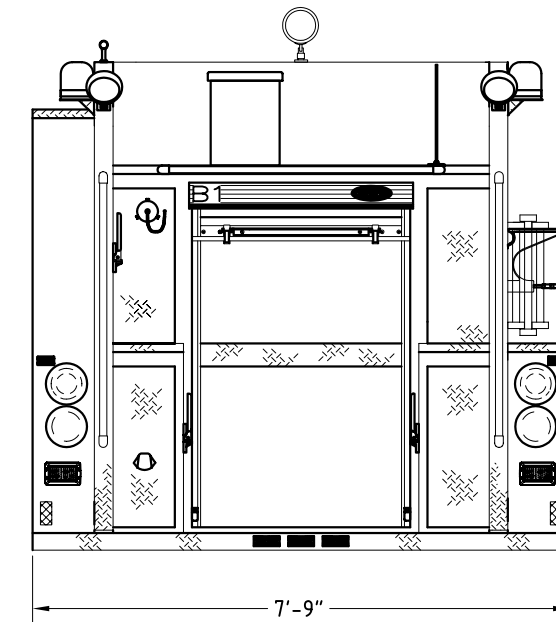

**CROSSLAY HEIGHT:**  
 (FOR REFERENCE ONLY)  
 TO RUNNING BOARD: 57"  
 TO GROUND: 81"

**HOSEBED HEIGHT:**  
 (FOR REFERENCE ONLY)  
 TO TAILBOARD: 64"  
 TO GROUND: 88"

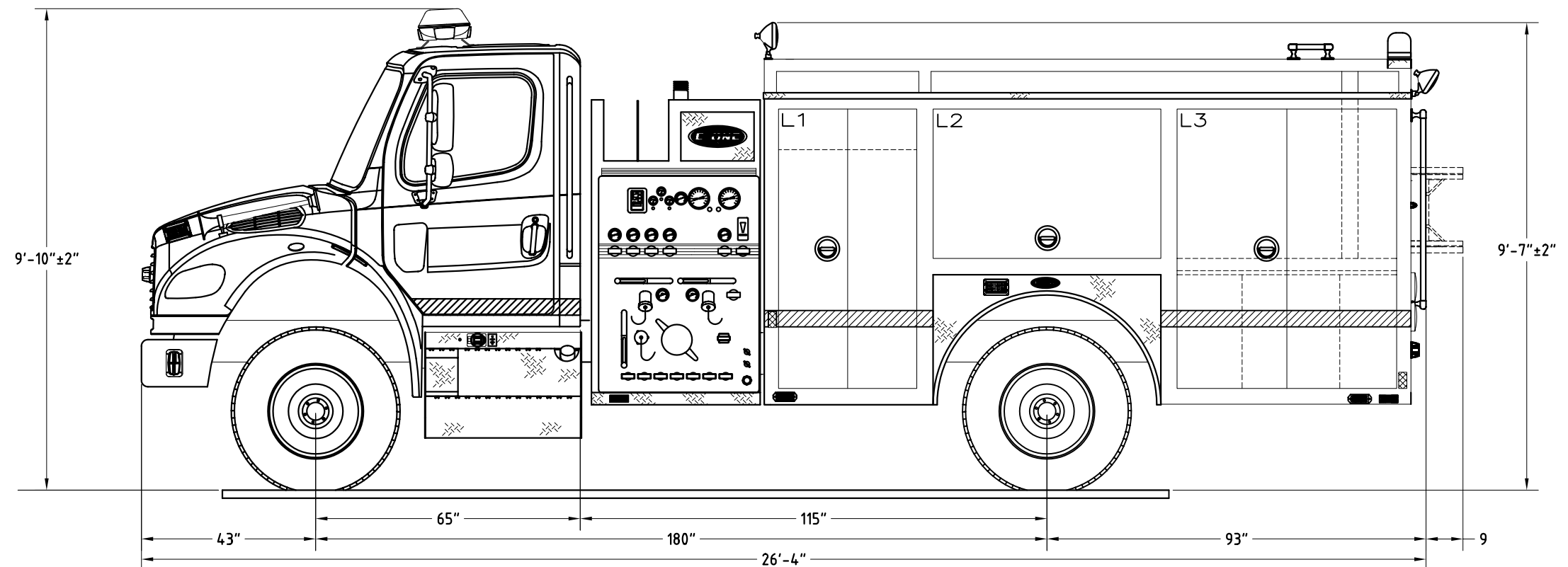

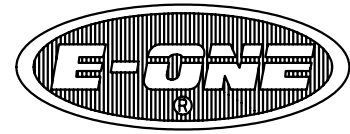

**E-ONE**  
**OCALA, FL**  
*SO.000000*

VT04 TRADITION PUMPER  
FREIGHTLINER M2 2DR

